



ROK CUP TROPHY 2025

TECHNICAL REGULATION

ROK CUP TROPHY 2025

TECHNICAL REGULATION

Approved by ACI Sport on 20/01/2025

The updates are indicated in the table:

UPDATE HISTORY

UPDATE	APPROVAL DATE	PAGE
CLARIFICATION AND ADDITION ARTICLE 1.1.3	05/02/2025	PAG 3



ROK CUP TROPHY 2025

TECHNICAL REGULATION

(This is just a translation, in case of interpretative conflicts, the Italian text approved by ACI SPORT will prevail)

Introduction

Although not expressly indicated in this Technical Regulation, reference is made to the 2025 ACI Sport Karting RDS Technical Regulation, 2025 CIK FIA Regulation and subsequent amendments and additions which are hereby fully reported.

1. CATEGORIES:

- MINI ROK
- MINI ROK U10
- JUNIOR ROK
- SENIOR ROK
- EXPERT ROK
- EXPERT ROK PLUS
- SUPER ROK
- SHIFTER ROK

1.1.1 MINI ROK

Engine: Vortex MINI ROK 60cc complying with the current MINI ROK engine identification sheet (technical fiche) approved by ACI SPORT.

Carburettor: **DELL'ORTO PHGB 18**, it must maintain its original structure, it shall mount the same parts and shall be the same as the ones in the engine identification sheet (technical fiche), in order to allow at any time, the comparison of all components with a new carburettor. **Any kind of processing, connection, polishing, addition or removal of material is forbidden.** The threaded clamp described in the engine identification sheet (technical fiche), screwed onto the carburettor, is used to fix the intake silencer; the clamp must not interfere inside the homologated carburettor inlet.

The only components of the carburettor that can be changed are those described in the table in the engine identification sheet (technical fiche).

Clutch: Concerning the clutch housing with holes, it is mandatory to use the cover according to the engine identification sheet (technical fiche) of the Mini ROK engine.

Ignition: Described in the engine identification sheet (technical fiche). The admitted spark plug is the one described in the Mini ROK engine identification sheet (technical fiche).

Chassis: Brand and model must hold **current CIK FIA MINI Gr.3 homologation**.

All homologated components of the chassis must hold current CIK FIA homologation (brake system, bodyworks, rear wheel protection).

Front fairing: Mounting kit complying with the RDS ACI SPORT Karting Technical Regulation 2025, art. 4.14.2 art. 4.14.3 comma a-b-c-d-e-f-g

Pre-Race checks: Every driver can use:

2 chassis of the same **Brand**

2 engines.

1.1.2 MINI ROK U10

Engine: Vortex MINI ROK U10 60cc complying with the current MINI ROK U10 engine identification sheet (technical fiche) approved by ACI SPORT.

Carburettor: **DELL'ORTO PHGB 18**, it must maintain its original structure, it shall mount the same parts and shall be the same as the ones in the engine identification sheet (technical fiche), in order to allow at any time, the comparison of all components with a new carburettor. **Any kind of processing, connection, polishing, addition or removal of material is forbidden.** The threaded clamp described in the engine identification sheet (technical fiche), screwed onto the carburettor, is used to fix the intake silencer; the clamp must not interfere inside the homologated carburettor inlet.

The only components of the carburettor that can be changed are those described in the table in the engine identification sheet (technical fiche).



ROK CUP TROPHY 2025

TECHNICAL REGULATION

(This is just a translation, in case of interpretative conflicts, the Italian text approved by ACI SPORT will prevail)

Clutch: Concerning the clutch housing with holes, it is mandatory to use the cover according to the engine identification sheet (technical fiche) of the Mini ROK U10 engine.

Ignition: Described in the engine identification sheet (technical fiche). The admitted spark plug is the one described in the Mini ROK U10 engine identification sheet (technical fiche).

Chassis: Brand and model must hold **current CIK FIA MINI Gr.3 homologation**.

All homologated components of the chassis must hold current CIK FIA homologation (brake system, bodyworks, rear wheel protection).

Front fairing: Mounting kit complying with the RDS ACI SPORT Karting Technical Regulation 2025, art. 4.14.2 art. 4.14.3 comma b-c-d-e-f-g

Pre-Race checks: Every driver can use:

2 chassis of the same **Brand**

2 engines.

1.1.3 ENGINE DISTRIBUTION

In the Mini ROK and Mini ROK U10 categories the races of the ROK Cup Italia 2025 will be held with the ENGINES provided and allocated by drawing lots by the Promoter and will be reserved to a limited number of drivers. The maximum number of admitted drivers will be specified in the ROK Cup Sporting Regulation 2025.

Depending on the number of drivers registered in the two categories, they may be combined for some stages or compete together for the whole event. In the latter case they will compete with separate rankings.

The maximum number of drivers allowed for each category may differ for some Rok Cup Italia 2025 rounds and in this case it will be specified in the Race Specific Regulations (RPG).

The same procedure might be applied to other races of the Rok Cup Trophy, if specified in the Specific Race Regulations (RPG) defining, from time to time, the maximum number of drivers admitted.

With ENGINE or ENGINES we mean: Mini ROK/Mini ROK U10 engine (according to the category attended) + carburettor + exhaust + intake silencer.

The engines and the parts supplied with it (Mini Rok/Mini Rok U10 engine, according to the category attended + carburetor + exhaust + intake silencer) will be identified with the same serial number and will be equipped with seals.

All drivers must have their own battery, battery support and wiring.

ENGINES will be distributed/assigned to each driver by drawing lots, and this will happen just before the official free practices in the presence of all drivers. The ENGINES must be used starting from the official free practices.

The ENGINE must be strictly original as supplied by the Promoter. It is not permitted to change, modify, add/remove any part, component, adjustment of the ENGINE or choose Options other than those provided.

At the end of each race session during the event, there might be a further draw for the ENGINE; in this case, each driver will be requested to leave the ENGINE and participate in a new draw.

Every time the drivers will return the ENGINES, a Vortex technician will verify eventual break, damages and/or missing parts and that seals are integral. In case of damaging and /or missing parts, the relating costs will be charged to the driver who has just returned the ENGINE.

ENGINES must be returned clean at the end of the race.

The cost of renting the ENGINE for each round of 2025 ROK Cup Italia 2025 is:

Euro 300,00 VAT included for the rental requests received by the Thursday of the week before the race.



ROK CUP TROPHY 2025

TECHNICAL REGULATION

(This is just a translation, in case of interpretative conflicts, the Italian text approved by ACI SPORT will prevail)

Euro 430,00 VAT included for the rental requests received from the Friday of the week before the race.

Registration to each race must be presented to the Organizer within the provided terms, while the renting of the ENGINE will be managed by the Promoter, according to the given instructions.

The cost of the ENGINE rental could differ for other ROK Cup Trophy events in which this procedure of ENGINES supplied by the Promoter will be applied and will be defined from time to time.

GEAR RATIO, CHAIN, REAR SPROCKET

Mini ROK category

For each race of the ROK Cup Italia 2025 and for the other races of the ROK Cup Trophy in which, as for the MINI ROK category, the ENGINES employed will be supplied by the Promoter, the gear ratio (engine sprocket/rear sprocket) to be used on the chassis will be indicated by the Promoter, with the tolerance of ± 1 tooth on the rear sprocket, according to the track, as indicated in the following table:

TRACK	ENGINE SPROCKET	REAR SPROCKET
SOUTH GARDA KARTING, LONATO (BS)	engine sprocket 11 teeth	rear sprocket 81 (± 1 tooth)
FRANCIACORTA KARTING TRACK, CASTREZZATO (BS)	engine sprocket 11 teeth	rear sprocket 77 (± 1 tooth)
CREMONA KARTING, CREMONA	engine sprocket 11 teeth	rear sprocket 77 (± 1 tooth)
7 LAGHI KART, CASTELLETTO DI BRANZUZZO (PV)	engine sprocket 11 teeth	rear sprocket 80 (± 1 tooth)
PISTA AZZURRA, JESOLO (VE)	engine sprocket 11 teeth	rear sprocket 83 (± 1 tooth)

Mini ROK U10 category

For each race of the ROK Cup Italia 2025 and for the other races of the ROK Cup Trophy in which, as for the MINI ROK U10 category, the ENGINES employed will be supplied by the Promoter, the gear ratio (engine sprocket/rear sprocket) to be used on the chassis will be indicated by the Promoter.

Rok Cup Winter Trophy, South Garda Karting - Lonato (BS), fixed gear ratio Mini ROK U10 category: engine sprocket 11 teeth / rear sprocket 81 teeth.

Furthermore, the following is specified:

-the chain to be used is always **the chain type "219"**

-the rear sprocket to be used is brand free, pitch 219 and the outline design of the rear sprocket must be the same as the one in the photo:

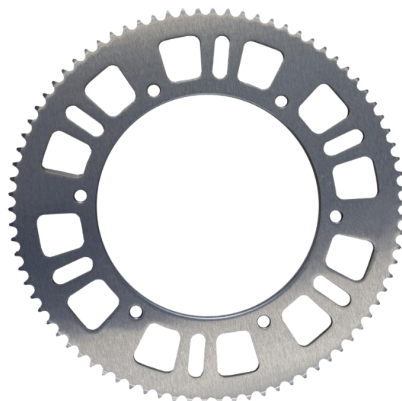



ROK CUP TROPHY 2025

TECHNICAL REGULATION

(This is just a translation, in case of interpretative conflicts, the Italian text approved by ACI SPORT will prevail)

1.1.4 TRANSPONDER POSITION

In the Mini ROK and Mini ROK U10 categories it is mandatory to position the transponder on the left side (brake caliper side) of the seat back as indicated in the photo, and not on the engine side.

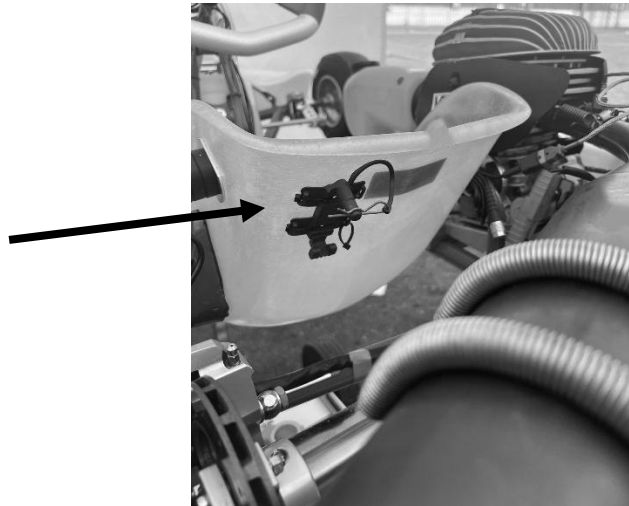

1.2 JUNIOR ROK

Engine: Vortex ROK GP JUNIOR 125cc complying with the current ROK GP JUNIOR engine identification sheet (technical fiche) approved by ACI SPORT.

Carburettor: DELL'ORTO VSHS 30, it must maintain its original structure, it shall mount the same parts and shall be the same as the ones in the engine identification sheet (technical fiche), in order to allow at any time, the comparison of all components with a new carburettor. **Any kind of processing, connection, polishing, addition or removal of material is forbidden. The only components of the carburettor that can be changed are those described in the table in the engine identification sheet (technical fiche).**

Cooling: Use of **only one (1)** radiator.

It is mandatory to use the original complete water pump, water pump pulley and radiator supplied with the engine.

The aforementioned parts must comply with the identification sheet (technical fiche) of the ROK GP JUNIOR engine.

Clutch: Concerning the clutch housing with holes, it is mandatory to use the cover according to the ROK GP JUNIOR engine identification sheet (technical fiche).

Chassis: Brand and model must hold current CIK FIA homologation or CIK FIA homologation of the previous homologation period, the use of bodyworks and rear wheel protection RDS ACI SPORT Karting Technical Regulation 2025 art. 4.14 and 4.15 is mandatory.

Front fairing: Mounting kit complying with the RDS ACI SPORT Karting Technical Regulation 2025, art. 4.14.2 – art. 4.14.3 comma b-c-d-e-f-g.

Pre-Race checks: Every driver can use:

2 chassis of the same **Brand**

2 engines.

1.3 SENIOR ROK - ROK EXPERT - ROK EXPERT PLUS

Engine: Vortex ROK SVR 125cc complying with the current ROK SVR engine identification sheet (technical fiche) approved by ACI SPORT.

Carburettor: DELL'ORTO VSHS 30, it must maintain its original structure, it shall mount the same parts and shall be the same as the ones in the engine identification sheet (technical fiche) in order to allow at any time, the comparison of all components with a new carburettor. **Any kind of processing, connection,**



ROK CUP TROPHY 2025

TECHNICAL REGULATION

(This is just a translation, in case of interpretative conflicts, the Italian text approved by ACI SPORT will prevail)

polishing, addition or removal of material is forbidden. The only components of the carburettor that can be changed are those described in the table in the engine fiche (technical fiche).

Cooling: Use of **only one (1)** radiator.

It is mandatory to use the original complete water pump, water pump pulley and radiator supplied with the engine.

The aforementioned parts must comply with the identification sheet (technical fiche) of the ROK SVR engine.

Chassis: Brand and model must hold current CIK FIA homologation or CIK FIA homologation of the previous homologation period, the use of bodyworks and rear wheel protection RDS ACI SPORT Karting Technical Regulation 2025 art. 4.14 and 4.15 is mandatory.

Front fairing: Mounting kit complying with the RDS ACI SPORT Karting Technical Regulation 2025, art. 4.14.2 – art. 4.14.3 comma b-c-d-e-f-g.

Pre-Race checks: Every driver can use:

2 chassis of the same **Brand**

2 engines.

1.4 SUPER ROK

Engine: Vortex ROK DVS 125cc complying with the current ROK DVS engine identification sheet (technical fiche) approved by ACI SPORT.

Carburettor: IBEA DVS or TILLOTSON SVS branded Rok DVS; the carburettor must maintain its original structure, it shall mount the same parts and shall be the same as the ones in the engine identification sheet (technical fiche), in order to allow at any time, the comparison of all components with a new carburettor. **Any kind of processing, connection, polishing, addition or removal of material is forbidden.**

Cooling: Use of **only one (1)** radiator.

It is mandatory to use the original OTK complete water pump, water pump pulley and radiator as per identification sheet (technical fiche) of the ROK DVS engine.

Chassis: Brand and model must hold current CIK FIA homologation or CIK FIA homologation of the previous homologation period, the use of bodyworks and rear wheel protection RDS ACI SPORT Karting Technical Regulation 2025 art. 4.14 and 4.15 is mandatory.

Front fairing: Mounting kit complying with the RDS ACI SPORT Karting Technical Regulation 2025, art. 4.14.2 – art. 4.14.3 comma b-c-d-e-f-g.

Pre-Race checks: Every driver can use:

2 chassis of the same **Brand**

2 engines.

1.5 SHIFTER ROK

Engine: Vortex SHIFTER ROK 125cc complying with the current SHIFTER ROK engine identification sheet (technical fiche) approved by ACI SPORT.

Carburettor: DELL'ORTO VSHS 30, it must maintain its original structure, it shall mount the same parts and shall be the same as the ones in the engine identification sheet (technical fiche) in order to allow at any time, the comparison of all components with a new carburettor. **Any kind of processing, connection, polishing, addition or removal of material is forbidden.**

Cooling: Use of **only one (1)** radiator.

It is mandatory to use the original OTK complete water pump, water pump pulley and radiator as per identification sheet (technical fiche) of the ROK SHIFTER engine.

Chassis: Brand and model must hold current CIK FIA homologation or CIK FIA homologation of the previous homologation period, the use of bodyworks and rear wheel protection RDS ACI SPORT Karting Technical Regulation 2025 art. 4.14 and 4.15 is mandatory.

Front fairing: Mounting kit complying with the RDS ACI SPORT Karting Technical Regulation 2025, art. 4.14.2 – art. 4.14.3 comma b-c-d-e-f-g.

Pre-Race checks: Every driver can use:



ROK CUP TROPHY 2025

TECHNICAL REGULATION

(This is just a translation, in case of interpretative conflicts, the Italian text approved by ACI SPORT will prevail)

2 chassis of the same **Brand**
2 engines.

2. TIRES

2.1 For the **Mini ROK and Mini ROK U10** category, admitted tires are the following:

- SLICK tires: LeVanto KRT 10x4.00-5/11x5.00-5
- RAIN tires: LeVanto MRT WET 10x4.00-5/11x5.00-5

2.2 For **Junior ROK, Senior ROK, Expert ROK, Expert ROK Plus, Super ROK and Shifter ROK** categories, admitted tires are the following:

- SLICK tires: LeVanto KRT 10x4.50-5/11x7.10-5
- RAIN tires: LeVanto KRT WET 10x4.20-5/11x6.00-5

The Specific Race Regulation of each ROK CUP TROPHY race might provide different provisions regarding the tyres models to be used.

With reference to the tire tolerances please note that the tolerance on the circumference is ±20mm measured with tire mounted on the wheel and with operating pressure (1 bar).

This measurement will be made by the technical Scrutineer in charge of the race.

2.3 PARC FERME' FOR TIRES

For all categories of the Rok Cup Trophy, for each single race, starting from the qualifying practices up to the final phase of the race, with the exception of the warm-up sessions, it is allowed the use of:

- one (1) set of new slick tires (1 set = 2 front slick tires + 2 rear slick tires).

The entrant can decide to use 1 optional slick tyre (1 front slick tyre or 1 rear slick tyre).

The complete set of tires and the optional tire will be delivered at the parc fermé, upon a VOUCHER to be purchased on the track at the Rok Center. These tires cannot be used during the warm-up sessions.

The management of tires will be done by Barcode system.

- minimum one (1) set / maximum two (2) sets of rain tires (1 set = 2 front rain tires + 2 rear rain tires), new or used at the entrant's discretion. These tires cannot be used during the warm-up sessions.

The management of tires will be done by Barcode system.

The number of tires, the brand and the model of tires as well as the management, distribution and check of tires might be different for some ROK CUP TROPHY races, if specified in the Specific Race Regulation (RPG).

For checks, see Art. 4.16 RDS ACI SPORT Karting Technical Regulation 2025.

3. FUEL AND LUBRICANT FOR FUEL MIXTURE

For all ROK Cup Trophy categories the lubricant to be used for the fuel mixture is ENI KART 2T.

For the checks, please refer to Art. 4.19 of the RDS ACI SPORT and Karting Technical Regulations 2025.

On the occasion of the Rok Cup Winter Trophy and of the ROK Cup Superfinal 2025 for all ROK categories (Mini ROK, Junior ROK, Senior ROK, Super ROK, Shifter ROK, Expert ROK, Expert ROK Plus) the fuel to be used will be PANTA 98-octane distributed directly at the track.

4. LUBRICANT

Counter shafts mechanism chambers and transmission gear set chamber must be filled with lubricant oil.



ROK CUP TROPHY 2025

TECHNICAL REGULATION

(This is just a translation, in case of interpretative conflicts, the Italian text approved by ACI SPORT will prevail)

5. MINIMUM WEIGHT FOR EACH CATEGORY

The minimum weight of kart + driver (in race conditions) for each category is the following:

MINI ROK	110 kg
MINI ROK U10	110 kg
JUNIOR ROK	145 kg
SENIOR ROK	160 kg
EXPERT ROK	170 kg
EXPERT ROK PLUS	170 kg
SUPER ROK	155 kg
SHIFTER ROK	180 kg

6. TECHNICAL CHECKS

During the technical checks, the specifications in this Technical Regulation, the engine identification sheets (technical fiches) duly approved by ACI SPORT registered together with this regulation, and the RDS ACI SPORT Karting Technical Regulation 2025 will be taken into consideration. **The tolerances described in the engine identification sheets are construction tolerances.**

General tolerances complying to ISO 2768-m, as here below reported:

ISO 2768-m	DEVIAZIONI CONSENTITE PER RANGE									
	DA	A	DA	A	DA	A	DA	A	DA	A
	0,5 mm	: 3 mm	> 3 mm	: 6 mm	> 6 mm	: 30 mm	> 30 mm	: 120 mm	> 120 mm	: 400 mm
QUOTE LINEARI	± 0,1 mm		± 0,1 mm		± 0,2 mm		± 0,3 mm		± 0,5 mm	
RAGGI ESTERNI	± 0,2 mm		± 0,5 mm		± 1 mm					
ALTEZZE SMUSSI	± 0,2 mm		± 0,5 mm		± 1 mm					

Moreover, the ACI SPORT Technical Scrutineer, upon authorization request to the Sporting Marshals, may at any time refer to any comparisons to value the conformity of any parts, with details provided by the promoter. The Technical Scrutineers also have the possibility, upon authorization request to the Sporting Marshals, to replace any part of the engine with an original spare part supplied by the promoter.

PROCEDURE FOR DELIVERY, USE AND RETURN OF SPARE PARTS IN PARC FERMÉ

Original spare parts, supplied by the promoter, will be randomly distributed by the Technical Scrutineers to the drivers/competitors indicated, inside the Parc Fermé, before the beginning of the race phase.

The spare parts received must be fitted to the kart, tested if necessary (specifically ignitions or coils) and used during the race phase indicated by the Scrutineers.

The correct assembly and use of the spare parts received is under responsibility of both drivers and their competitors.

Spare parts must be returned to the Scrutineers at the end of the race phase, always inside the parc fermé.

Original spare parts, supplied by the promoter, will be recognisable by a marking/sealing/adhesive seal or other.

For the delivery of some original spare parts, supplied by the promoter, the following procedure could be used:

- 1) The Technical Scrutineers inform the drivers to show up in parc fermé without their own spare parts, for which it was decided to use the original spare parts supplied by the promoter.
- 2) The Technical Scrutineers give each driver an identification card reporting his race number.
- 3) The Technical Scrutineers give the original spare parts supplied by the promoter to the drivers upon delivery of their identification card.
- 4) Drivers use the original spare parts supplied by the promoter during the race phase concerned.



ROK CUP TROPHY 2025

TECHNICAL REGULATION

(This is just a translation, in case of interpretative conflicts, the Italian text approved by ACI SPORT will prevail)

- 5) At the end of the race phase, the drivers return the original spare parts supplied by the promoter to the Technical Scrutineers, upon receipt of their identification card.

And this way for all phases of the race in which the Technical Scrutineers decide to use the original spare parts supplied by the promoter.

- 6) At the end of the last phase of the race, the drivers return the original spare parts supplied by the promoter to the Technical Scrutineers without receiving their identification card back, which will be held by the Technical Scrutineers.

6.1 MARKING

Each part of the following MINI ROK, MINI ROK U10, ROK SVR, ROK GP JUNIOR, ROK DVS, ROK SHIFTER engines has a mark which allows the recognition and ensures the originality and the conformity of the part during the technical checks.

The marks used for marking the parts are those below:



6.2 EXHAUST MANIFOLD AND INLET GASKETS

Exhaust manifolds and inlet gaskets sealing cannot be anyhow decreased, restricted or blocked.

7. PROCEDURE FOR MEASURING THE VOLUME OF THE COMBUSTION CHAMBER

1. Remove the engine from the chassis;
2. Wait until the engine is at room temperature (the organizer must supply appropriate cooling fans);
3. Remove the cylinder head to check the protrusion of the spark plug inside the combustion chamber;
4. Remove the spark plug (check the 18.5 mm dimension);
5. Screw the plug insert in place of the spark plug (the plug insert, tightened on the cylinder head, must not extend beyond the upper part of the combustion chamber. It must be fixed to the head cylinder exactly in the same way as the spark plug measuring 18.5 mm);
6. Make the top part of the piston and the periphery of the cylinder waterproof using grease;
7. Place the piston at top dead centre and block the crankshaft;
8. Carefully remove the exceeding grease;
9. Make sure the engine lies flat;
10. Place the cylinder head back and screw it in at the tightening torque recommended by the Manufacturer;
11. With a laboratory graduated burette (mechanical A-type or electronic), fill the combustion chamber with "CASTROL ATF DEXRON" VI (6) "RED" type OIL to the uppermost part of the top edge of the plug insert;



ROK CUP TROPHY 2025

TECHNICAL REGULATION

(This is just a translation, in case of interpretative conflicts, the Italian text approved by ACI SPORT will prevail)

12. The measured volume must be as requested and determined by RDS and described in the following table, for each class.

Table of the minimum value of the combustion chamber volume, of the classes mentioned below:

Category	Volume of the combustion chamber	
MINI ROK/MINI ROK U10	4,8cm ³ . + insert 2 cm ³	6,8cm³ Min.
ROK GP Junior	7,5cm ³ + insert 2 cm ³	9,5cm³ Min.
ROK SVR	8,7cm ³ + insert 2 cm ³	10,7cm³ Min.
ROK DVS	9cm ³ + insert 2 cm ³	11cm³ Min.
ROK SHIFTER	11cm ³ + insert 2 cm ³	13cm³ Min.

Plug Insert Dimensions

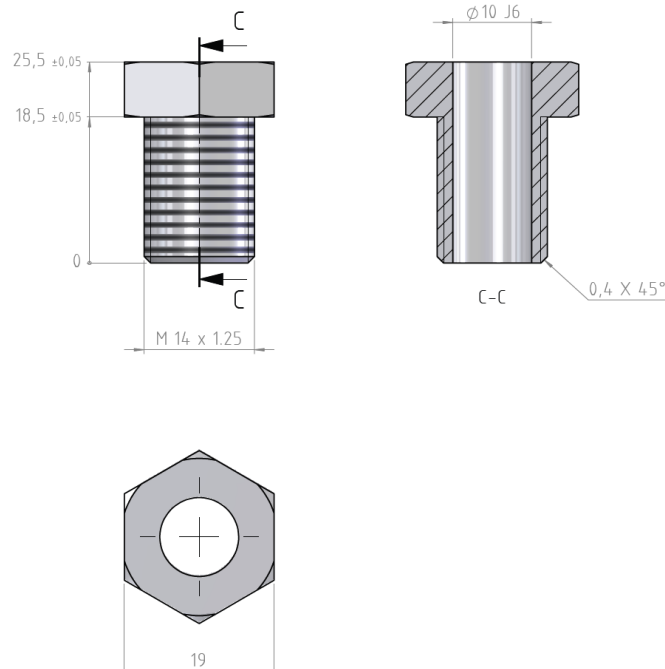

(This is just a translation, in case of interpretative conflicts, the Italian text approved by ACI SPORT will prevail)

7.1 PROCEDURE FOR MEASURING THE MINIMUM DISTANCE BETWEEN THE SEAT OF THE POWER VALVE AND THE PISTON

1. Wait until the engine is at room temperature (the organizer must supply appropriate cooling fans).
2. Remove the valve system.
3. Assemble the gauge number 0428730040 supplied by Vortex in place of the valve system.
4. Insert and slide the gauge 8011 for the ROK GP JUNIOR engine and the gauge 8012 for the ROK DVS engine as shown in the picture.
5. The gauges 8011 and 8012 must lean against the flat surface of the gauge mounted in place of the valve system without touching the piston skirt.
6. In case of contact of the gauge 8011/8012 against the piston, check the distance between the gauge 8011/8012 and 0428730040 with a feeler gauge.

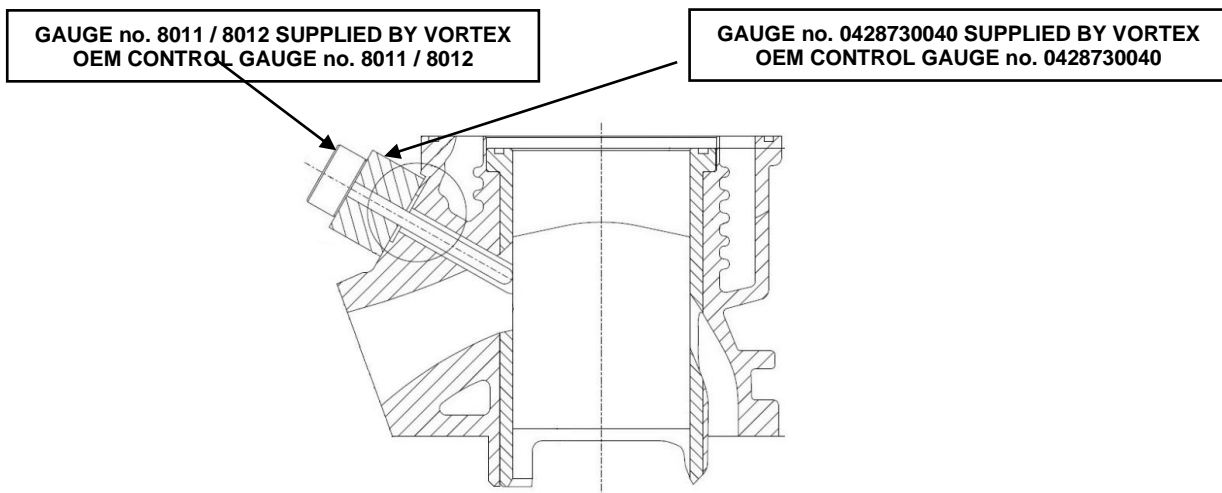

8. TOOL FOR MEASURING THE ENGINE DISTRIBUTION

For all ROK categories where the control is required, the exhaust opening angle, inlet opening angle, transfer opening angle and angle between exhaust and inlet must be measured with a 0,20 mm thick and 5 mm wide wedge (see drawing below).

The reading is made by using a digital display with encoder measuring device, or with minimum diameter 200 mm graduated disc.

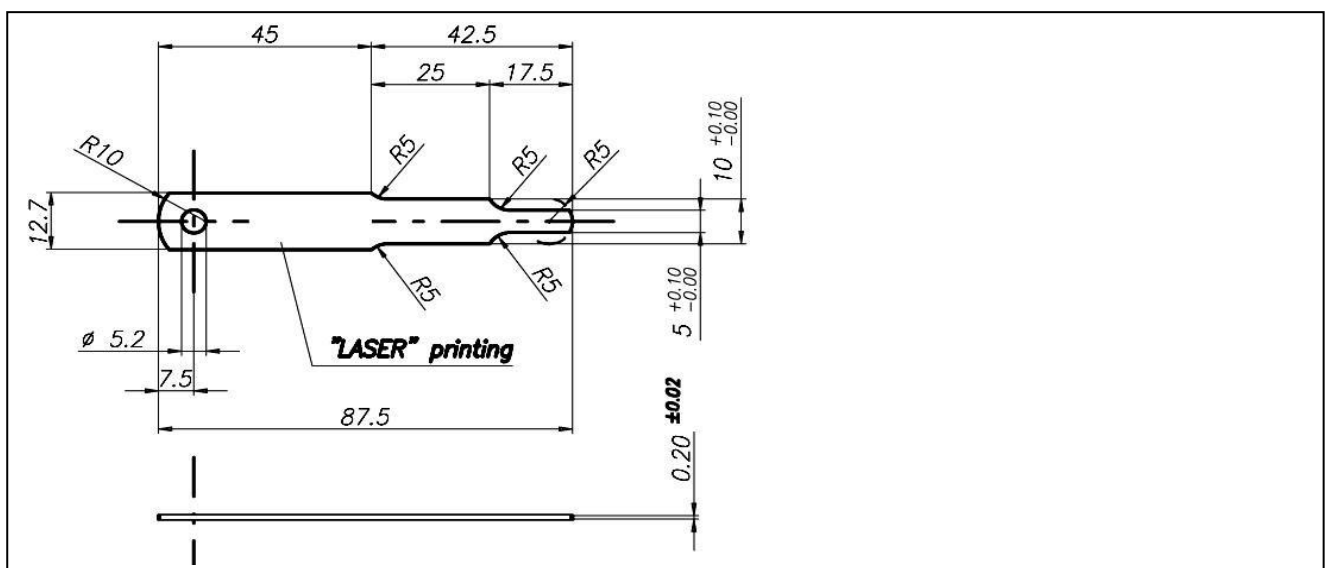

(This is just a translation, in case of interpretative conflicts, the Italian text approved by ACI SPORT will prevail)

8.1 CONTROL OF THE ADMISSION GAP OF MINI ROK/MINI ROK U10 ENGINE

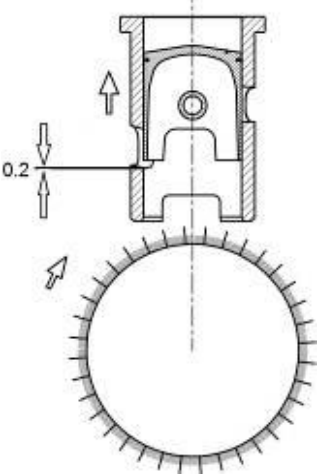
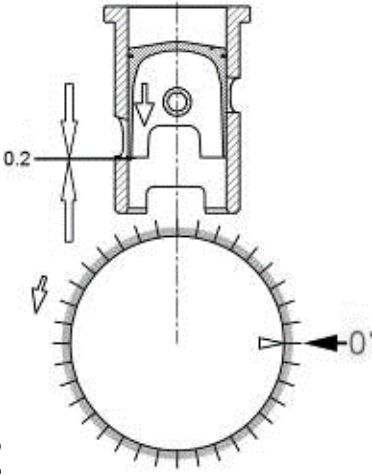
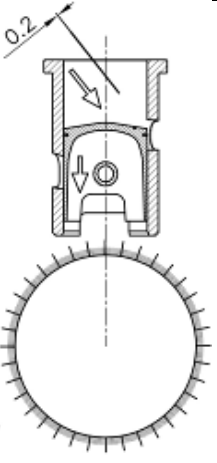
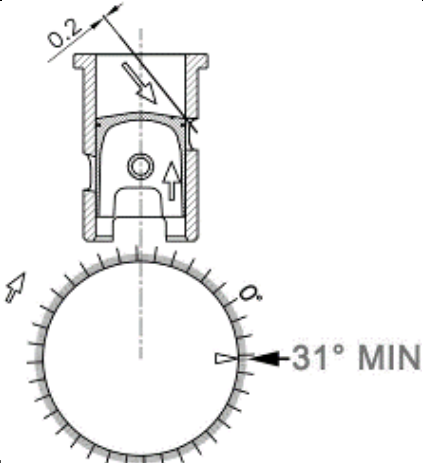
 <p>1</p>	 <p>2</p>
<p>RUOTARE IN SENSO ORARIO PER ALZARE IL PISTONE E PERMETTERE L'INSERIMENTO DELLO SPESSIMETRO CONTRO LO SPIGOLO INFERIORE DELL'ASPIRAZIONE</p> <p>TURN CLOCKWISE AND LIFT THE PISTON TO ALLOW THE INSERTION OF THE FEELER GAUGE AGAINST THE LOWER INLET EDGE</p>	<p>RUOTARE IN SENSO ANTIORARIO PER ABBASSARE IL PISTONE FINO AD INCONTRARE LO SPESSIMETRO APPOGGIATO ALLO SPIGOLO DELL'ASPIRAZIONE IN QUESTA FASE SETTARE LA POSIZIONE DI 0°</p> <p>TURN COUNTERCLOCKWISE AND LOWER THE PISTON UNTIL IT MEETS THE FEELER-GAUGE RESTING AT THE EXHAUST EDGE, AT THIS STAGE SET THE SCALE ON THE POSITION OF 0 DEGREES</p>
 <p>3</p>	 <p>4</p>
<p>LIBERARE LO SPESSIMETRO QUINDI RUOTANDO IN SENSO ANTIORARIO ABBASSARE IL PISTONE PER PERMETTERE L'INSERIMENTO DELLO SPESSIMETRO SOTTO LO SPIGOLO SUPERIORE DELLO SCARICO</p> <p>RELEASE THE FEELER GAUGE AND TURNING COUNTERCLOCKWISE LOWER THE PISTON TO ALLOW THE INSERTION OF THE FEELER GAUGE UNDER THE UPPER EDGE OF THE EXHAUST</p>	<p>RUOTANDO IN SENSO CONTRARIO ALZARE IL PISTONE FINO AD INCONTRARE LO SPESSIMETRO APPOGGIATO ALLO SPIGOLO DELLO SCARICO E CONTROLLARE CHE L'ANGOLO DI SPOSTAMENTO NON SIA INFERIORE A 31°</p> <p>TURN CLOCKWISE TO LIFT THE PISTON UNTIL IT MEETS THE FEELER GAUGE RESTING AT THE EXHAUST EDGE. AT THIS STAGE CHECK THAT THE EDGE OF DISPLACEMENTS OF THE VERNIER MATCHES NOT LESS THAN 31 DEGREES</p> <p>The edge of displacements of the vernier match not less than 31 degrees</p>



ROK CUP TROPHY 2025

TECHNICAL REGULATION

(This is just a translation, in case of interpretative conflicts, the Italian text approved by ACI SPORT will prevail)

8.2 SQUISH HEIGHT MEASUREMENT

Squish height measurement must be done by means of 1.5 mm size round soldering wire.

8.3 TECHNICAL CHECK CONSULTANT and TECHNICAL CHECKS

On the occasion of each race and for the technical checks of the engine only, the Promoter OTK Kart Group may request the presence of his own specialized technician to support the Technical Scrutineers. The check of the chassis and other details is assigned to ACI SPORT Technical Scrutineers. The procedures for the technical check of the engine and/or any other parts must be performed only by Technical Scrutineers appointed by ACI SPORT for the event, in compliance with the 2025 RDS ACI SPORT Karting; for any complaints and/or appeals refer to 2025 RNS ACI SPORT.

Moreover, the Sporting Scrutineers may request the parts to be deeper checked at the Manufacturer's headquarters. This request, duly justified and described, must be done by the Technical Scrutineer to the Sporting Scrutineers.

The Promoter or the Organizer will deliver the part/s duly sealed with the relating official document of the Sporting Scrutineers and Technical Scrutineers to the Manufacturer of the part/s.

The parts will be checked at the Manufacturer's seat, by the presence of the entrant and the Technical Scrutineer.

Tests/crash tests can be done on such parts.

The parts no longer usable will be replaced by the Promoter OTK Kart Group srl only in case of proven compliance.

The parts no longer usable and replaced by the Promoter OTK Kart Group srl will not be returned to the entrant. The Technical Scrutineer will then send the check result to the President of the Sporting Scrutineers.

The logistic costs will be paid by the Promoter OTK Kart Group srl if the part/s is/are respecting the Regulations, otherwise the entrant will pay them.

9. CLUTCH

For **all ROK categories**:

- the clutch must be dry; any type of internal lubrication is forbidden.

For the **Junior ROK - Senior ROK - Expert ROK - Expert Plus ROK** categories, in addition to the provisions of the engine identification sheets (technical fiches), the following clutch checks are admitted with driver onboard:

- from stationary position in pre-grid and at the end of the race, in order to verify the first engagement of the clutch at 4000 rpm (after checking the whole weight); the clutch must be 100% direct-drive at the minimum 5000 rpm in all conditions;
- through the UNILOG** data acquisition system provided by the Promoter, in order to verify the direct-drive of the clutch in all conditions;
- through speed bump.

For the **Mini ROK and Mini ROK U10** category, in addition to the provisions of the engine identification sheets (technical fiches), the following clutch checks with driver onboard are admitted:

- from stationary position in pre-grid and at the end of the race, in order to verify the first engagement of the clutch at 3500 rpm (after checking the whole weight); the clutch must be 100% direct-drive at the minimum 4500 rpm in all conditions;
- through the UNILOG** data acquisition system provided by the Promoter, in order to verify the direct-drive of the clutch in all conditions;
- through speed bump.



ROK CUP TROPHY 2025

TECHNICAL REGULATION

(This is just a translation, in case of interpretative conflicts, the Italian text approved by ACI SPORT will prevail)

****Any braking or damage to the UNILOG device supplied for the event is under the entrant's responsibility.**

10. RACING SPORTSWEAR

It is mandatory for drivers of all ROK Cup Trophy categories to use racing sportswear (**racing suit and helmet**) complying with homologation and safety measures provided by ACI SPORT and CIK-FIA.

11. TRANSMISSION

For all Rok categories, with the exception of the Shifter Rok category, it is allowed only the use of the engine sprocket and the rear sprocket for chains type "219".

For the check of the chain type "219", see the drawing below.

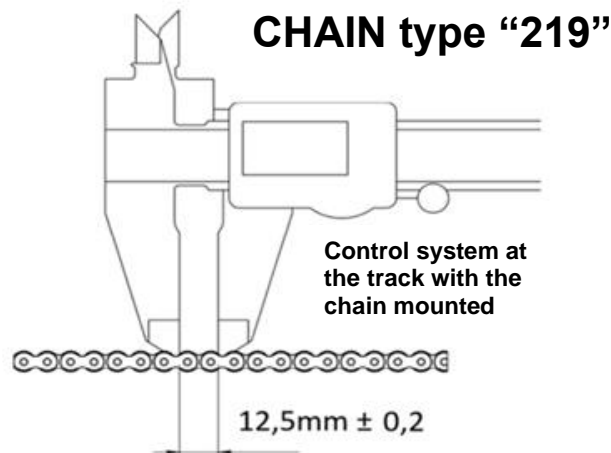

Sprocket: The sprocket to be used is a free brand, pitch 219 and the design of the sprocket profile must be like the one in the picture

